

Slewing Drive Performance Parameters		
Rated Output Speed	3rpm	
Output Torque	5.21 kN.m	3.85x10 <sup>3</sup> lbf.ft
Tilting Moment	41.2 kN.m	30.4x10 <sup>3</sup> lbf.ft
Holding Torque	38.7 kN.m	28.5x10 <sup>3</sup> lbf.ft
Static Axial Load Rating	670 kN	150.7x10 <sup>3</sup> lbf
Static Radial Load Rating	280 kN	63x10 <sup>3</sup> lbf
Gear Ratio	59:1	
Precision	≤0.17°	
Hydraulic motor Performance Parameters		
Pressure	10MPa	
Flow	30L/min	

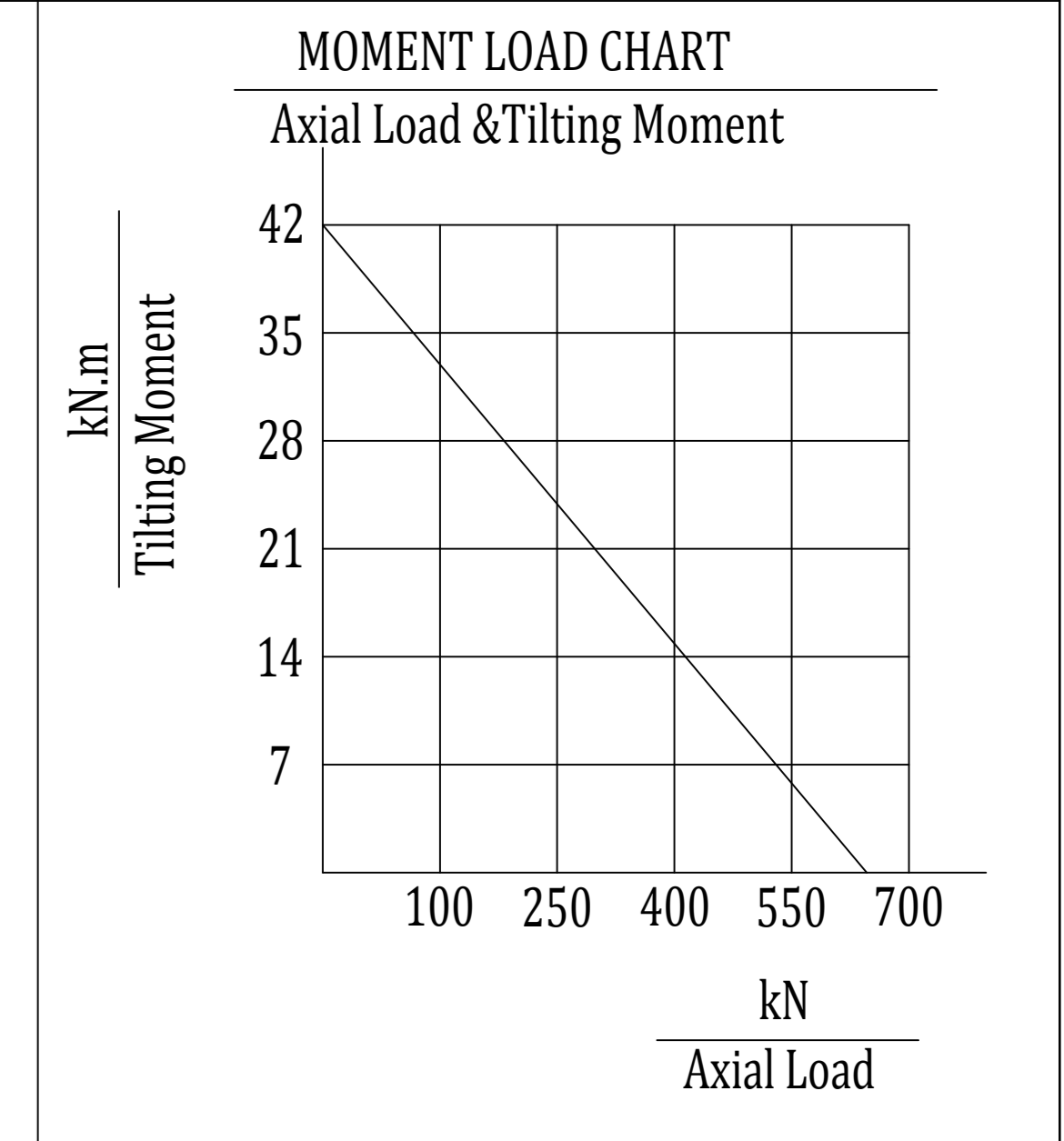

Hydraulic Motor Performance Data  
BMRS160 [157.2 cm<sup>3</sup>/rev.]

Flow (L/min)	Pressure (MPa)							
	5	7	9	10	12	14	16	17.5
10	115	160	203	220	260	300	340	362
20	58	55	52	50	44	38	34	26
30	114	160	205	230	265	320	355	380
40	119	115	111	108	103	95	84	76
50	105	158	202	221	261	305	344	378
60	184	181	177	172	165	153	134	130
70	100	145	196	218	257	299	340	374
75	246	244	239	237	230	218	199	184
continue (max.)	90	140	190	209	250	295	336	366
intermittent (max.)	307	305	302	300	292	280	262	244
	84	136	180	199	240	286	330	360
	370	368	364	362	355	342	334	304
	65	120	164	180	223	280	320	350
	435	434	430	427	416	405	385	366
	59	116	158	175	220	272	314	342
	465	462	458	456	447	433	416	395

Torque (N.m) 378  
Speed (rpm) 130

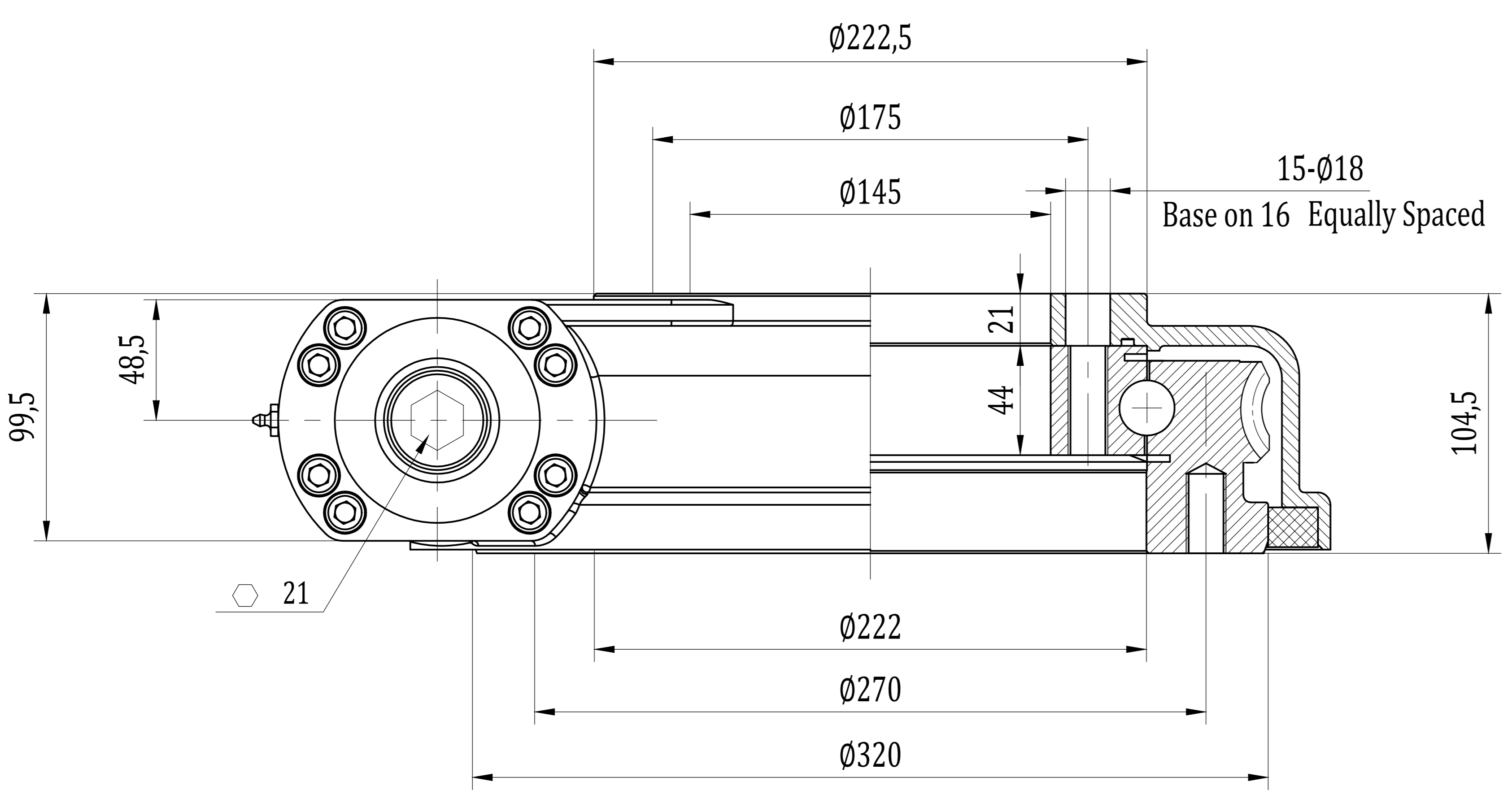
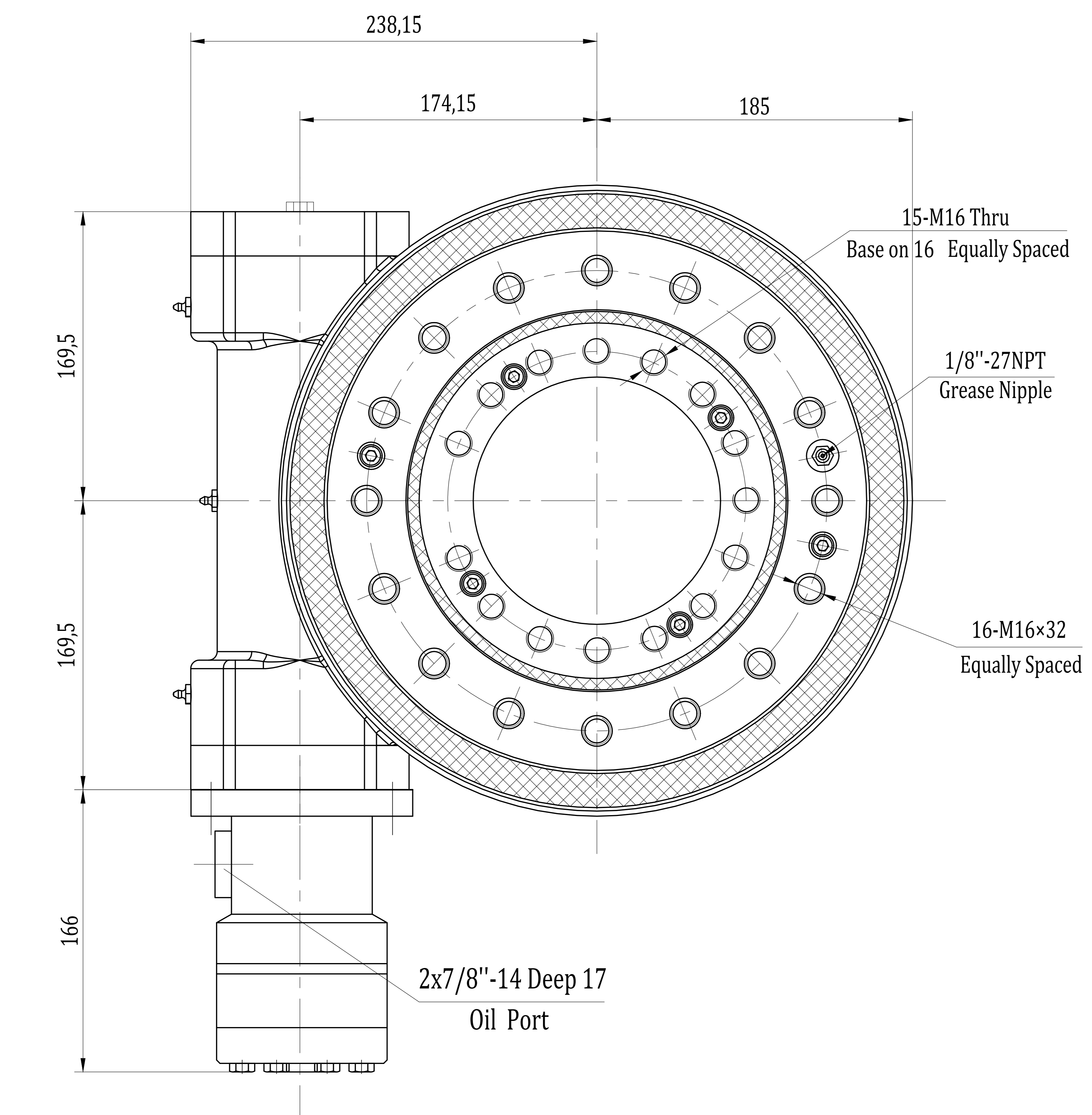

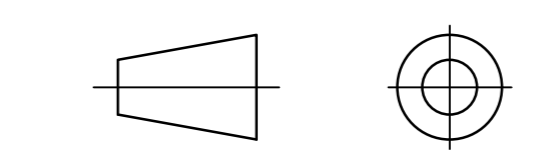
REV	DATE	REVISER	REVISER	
DESIGNED BY	2024/6/13	Li Ming	 www.coresundrive.com Coresun Drive Equipment Changzhou Co., Ltd.	
CHECKED BY	2024/6/13	Rui Wang		
APPROVED BY	2024/6/13	Shane Zhang		
ALL PROPRIETARY RIGHTS IN THE SUBJECT MATTER HERE OF ARE RESERVED, AND NO PERMISSION IS GRANTED OR TO DISCLOSE REPRODUCE THIS PRINT IN WHOLE OR IN PART, ANY OF THE INFORMATION TO OTHERS.			WEIGHT	SCALE
SYMBOLE ISO				1:3
				A3
			SHEET	1/1
			Slewing Drive	
WH9-59-RH-160A		A		